

PW-300DSA

Intelligent Point Type Photoelectric Smoke Detector

Description

PW-300DSA intelligent point type photoelectric smoke detector, using the light scattering technology to implement the detection of smoke. It's especially suitable for detecting the smoke generated in the initial or smoldering combustion stage.

Built-in special microprocessor, using surface mounted technology(SMT) production, having strong anti-corrosion, anti-moisture and anti-interference ability, using advanced algorithms for accurate calculation, the detector effectively prevent false alarm.

Using SLC communication, electronic address programming, occupy one address. Mixed addressing with other detectors or modules, making on-site wiring, installation and commissioning more convenient.



Features

- Responds well to slow burning, smoldering fires.
- Well suited for accommodation decks, passages and escape routes.
- Unaffected by wind or atmospheric pressure.
- Rejection of transient signals.
- Remote test feature.
- Five approved response modes to EN 54.
- Soft Addressing: the device address can be set by a programmer.

NOTE: For system compatibility and feature support of this device, please refer to your chosen panel manufacturer.

Specifications

Detection Principle: Photo-electric detection of light scattered in a forward direction by smoke particles.

Chamber Configuration: Horizontal optical bench housing an infrared emitter and sensor arranged radially to detect forward scattered light.

Sensor: Silicon PIN photo-diode.

Emitter: GaA/As infra-red light emitting diode.

Sampling Frequency: Once per second.

Supply Wiring: Two wire supply, polarity sensitive.

Terminal Functions: L1&L2: Supply in & out connections.

+R: Remote indicator positive connection.

-R: Remote indicator negative connection.

Digital Communication: Core Lite compatible.

Communication Protocol Voltage: 5V – 9V peak to peak.

Supply Voltage (Vmin-Vmax): 17V – 28V DC.

Quiescent Current: 300µA.

Alarm Indicator: One clear viewable light emitting diode (LED) illuminating red. Optional remote LED.

Alarm Current, LED Illuminated: 1 mA.

Clean-air Analogue Value: 23 +4/-0.

Alarm Level Analogue Value: 55.

Operating Temperature: -10°C ~ 55°C.

Storage Temperature: -40°C ~ 80°C.

Humidity: 0% - 95%RH (non-condensing).

IP Rating: IP44.

Dimension: 99.5mm(D) × 40.5mm(H) (not including base).
48.5 mm height with base.

Weight: 97g (not including base).

Housing Material: White flame-retardant polycarbonate.

Terminals Material: Nickel plated stainless steel.

Standard: GB4715-2005 & EN54-7:2018 by UL.

Approvals: CCCF & UL.
CCC-Mark & UL-EU-Mark.

Operation

The Optical Smoke Detector has a white moulded polycarbonate case with wind-resistant smoke inlets. The indicator LEDs are colourless when the detector is in quiescent state and red in alarm. Within the case is a printed circuit board which on one side has the light proof labyrinth chamber with integral gauze surrounding the optical measuring system and on the other has the signal processing and communications electronics.

An infrared light emitting diode within its collimator is arranged at an obtuse angle to the photo-diode. The photo-diode has an integral daylight blocking filter.

The IR LED emits a burst of collimated light every second. In clear air the photo-diode receives no light directly from the IR LED because of the angular arrangement and the chamber baffles. When smoke enters the chamber it scatters light from the emitter IR LED onto the photo-diode in an amount related to the smoke characteristics and density. The photo-diode signal is processed to provide an analogue value for transmission when the detector is interrogated.

Schematic Diagram

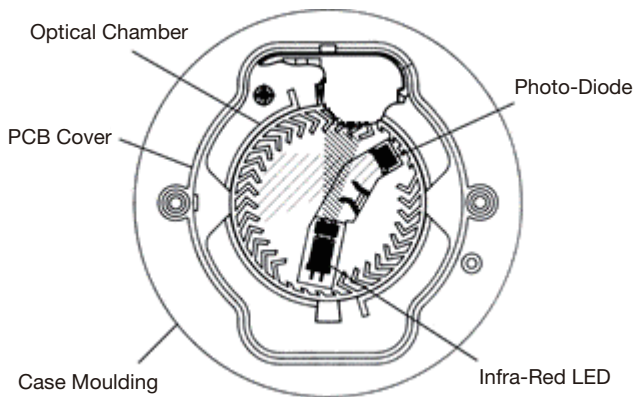

Electrical Description

The Addressable Optical Smoke Detector is designed to be connected to a two-wire loop circuit carrying both data and a 17V to 28V DC supply. The detector is connected to the incoming and outgoing supply via terminals L1 and L2 in the mounting base. A remote LED indicator requiring not more than 4mA at 5V may be connected between the +R and -R terminals. The detector is calibrated to give an analogue value of 23 +4/-0 counts in clean air. This value increases with smoke density. A count of 55 corresponds to the alarm level analogue value.

Response Modes

Addressable Optical Smoke Detectors can be operated in any one of five EN54 approved response modes below, which can be selected through the fire control panel. Each mode corresponds to a unique response behaviour, which is related to sensitivity to fire. Mode 1 gives a higher sensitivity to fire than Mode 5.

Response Times

Mode	Alarm threshold (%/m)	dB/m	Minimum time to alarm (Seconds)
1	1.4	0.08	5
2	1.4	0.08	30
3	2.1	0.12	5
4	2.1	0.12	30
5	2.4	0.14	5

Flashing LED

Addressable Optical Smoke Detectors have a single integral LED indicator, which can be illuminated by the fire control panel to indicate detectors in alarm. A flashing LED mode can also be programmed to activate each time the detector is polled.

Remote Test Feature

The remote test feature is enabled from the fire control panel. On receipt of the command signal from the fire control panel, the detector is forced electrically into alarm. An analogue value of 85 is returned to the fire control panel to indicate that the detector is working correctly.

Rejection of transient signals

This detector is designed to give low sensitivity to very rapid changes in the sensor output, since these are unlikely to be caused by real fire conditions, resulting in fewer false alarms.

Drift Compensation

Addressable Optical Smoke Detectors include compensation for drift in the sensor output due to dirt in the chamber, which maintains the sensitivity at a constant level. This increased stability is achieved without significantly affecting the detectors sensitivity to fire whilst still meeting the requirements of the EN54 and GB standards.

Installation

The detector can be installed with two different types of detector base which is BSL300-A(4 terminals) or B300-A(2 terminals).